

AMI Your Way

Neptune® R900® System: Cellular Endpoint



Neptune's cellular endpoint allows you to progress at your own pace to AMI when integrated into your Neptune® R900® System. Neptune's cellular endpoint provides all of the benefits of an advanced meter reading solution without the operational burden of network infrastructure while allowing you to protect existing asset investments. An easily deployable AMI solution, the cellular endpoint allows you to start collecting actionable meter data immediately. Powered by the FirstNet® cellular network, you are assured a reliable, highly secure, and easy-to-deploy AMI data solution for both current and future needs.

- No AMI fixed network infrastructure installation, maintenance, operations, or upgrade costs for the life of the deployment.
- Seamless integrations with existing R900 technology for a flexible AMI solution.
- Access all of your meter data from anywhere at any time with Neptune® 360™.
- Improve operations and customer service with real-time, high-resolution AMI data and advanced analytics.
- Automatically recover from network outages with 96 days of stored data.

FirstNet®, Built with AT&T

- Two-way solution using the FirstNet® LTE-M cellular technology helps ensure robust coverage.
- Prioritized connectivity, even during natural disasters, protects against commercial traffic congestion.
- Network resources and mobile cell sites can be dispatched during disaster recovery to support network connectivity.
- Sensitive information is highly secure on the FirstNet® network.

Specifications

Environmental Conditions

- Operating temperature:
-22°F to +149°F (-30°C to +65°C)
- Storage temperature:
-40°F to +158°F (-40°C to +70°C)
- Operating humidity:
100% condensing

Antennas

- Wall: standard internal antenna
- Pit: internal or external antenna

Encoded Register Compatibility

- Neptune® MACH 10®, ARB®V, ProRead™, E-CODER®, and ProCoder™
- Sensus ECR II, ICE, iPerl, Electronic Register and OMNI
- Hersey/Mueller Translator
- Badger ADE, HR E|LCD, E-Series
- Elster/AMCO InVision (Sensus protocol version)

Operation

- Regular cellular LTE-M transmissions with configurable transmission windows
- Mobile 900 MHz backup transmissions
- Verify installation via the cellular endpoint manager tool
- 15-minute interval data with automatic back-fill
- Priority alerts

Warranty

- Neptune provides a limited warranty for performance, materials, and workmanship. See warranty statement for details.

Dimensions

Wall Endpoint

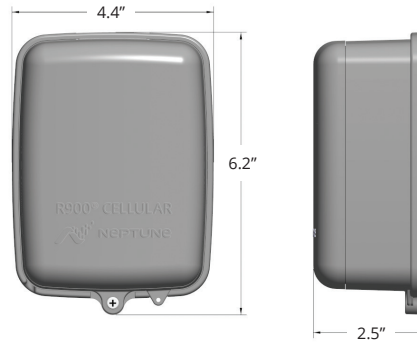

Pit Endpoint (Internal Antenna)

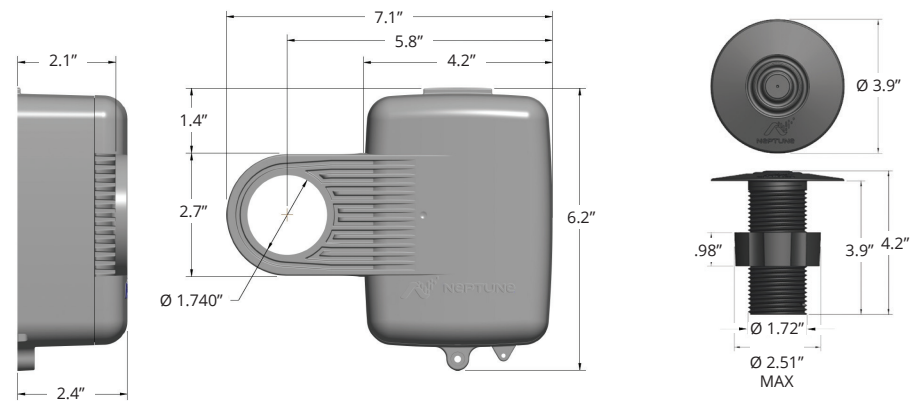

Pit Endpoint with External Through-the-Lid Antenna

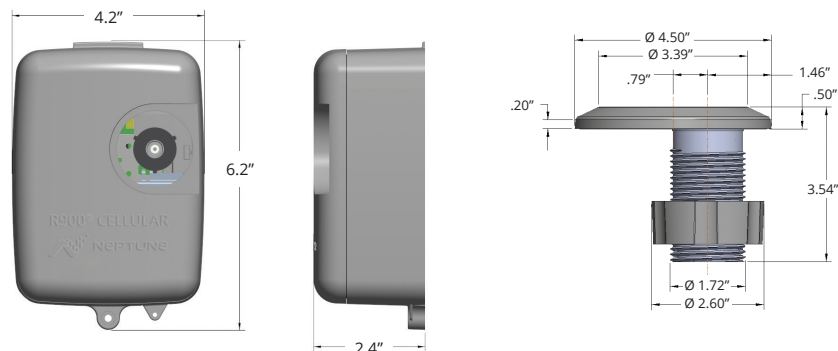

©2023 AT&T Intellectual Property. FirstNet, First Responder Network Authority, and FirstNet logo are registered trademarks and service marks of FirstNet, an independent authority within the U.S. Department of Commerce. All other marks are the property of their respective owners.

©2023 Neptune Technology Group Inc. All Rights Reserved. The trademarks, logos and service marks displayed in this document herein are the property of Neptune Technology Group Inc., its affiliates or other third parties. Availability and technical specifications are subject to change without notice. 23-009650 PS R900 CELLULAR ENDPOINT-US 03.23



Neptune Technology Group
1600 Alabama Highway 229
Talladega, AL 36078
800-633-8754 f 334-283-7293